

PRESSURE/LEVEL TRANSMITTER MODEL 551 COMPACT SIZE

TS 551

FEATURES

- Small Size For Tight Places
- Two Wire Loop Powered
- 4-20 mADC, Intrinsically Safe
- Integral Electronics/Sensor Module
- Surface Mount Silicon Electronics
- Used For Pressure Or Level Measurement
- NPT, ANSI, DIN, or JIS Process Connection
- Ranges, From 12 Inches Water To 3000 PSI
- Zero & Span Pots For Field Recalibration
- Spark & Voltage Surge Protection
- Maintenance Operation

DESCRIPTION

The Model 551 Pressure Transmitter incorporates Both the sensor and the electronics in a module mounted in a heavy duty body. Its compact size makes it ideal for very limited space conditions.

The sensor includes an oil filled 316-L S.S. or platinum diaphragm which isolates the strain gage Bridge from the process liquid or gas. The back of the sensor is usually vented to atmosphere to compensate for barometric pressure changes.

APPLICATION

The Model 551 is used to measure and transmit the pressure of liquids and gases in pipelines, tanks, ducts and other containments.

The 551 is commonly used as a liquid level transmitter in vented tanks. The pressure at the bottom of a vented tank containing a liquid is linearly proportional to the height and density of the liquid.

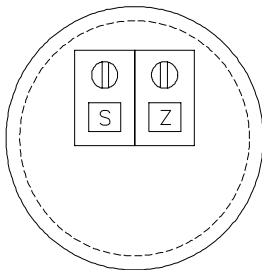

CALIBRATION ADJUSTMENTS
(TOP VIEW SHOWN WITHOUT
HOUSING IN PLACE)



1" MPT, FLIP-TOP HOUSING



1/2" FPT, S.S. HOUSING

SPECIFICATIONS

Technology: Silicon Strain gage.

Supply Power: 13 to 35 VDC, 2 Wire loop powered

Output: 4-20 mADC isolated, Intrinsically Safe

Loop Impedance: 550 Ω @ 24 VDC, 1100 Ω @ 35 VDC

Adjustments: Span from 30% to 100% of sensor range.

Zero to 30% basic and to 80% optionally,
non-interactive.

Over Pressure: 2X Range (35 PSI min) without damage

3X Range (1000 PSI min) without rupture

Temperature Range: -20 to +220°F (Process)

-20 to +180°F (Electronics)

30 to +130°F (compensated)

Accuracy: $\pm 0.25\%$ F.S. or better

Thermal Error: $\pm 0.02\%$ F.S./°F maximum

Barometric Effect: None

OPTIONAL FEATURES

1/2" NPTM condensate pigtail for steam service.

DELTA CONTROLS CORP

MODEL NUMBERING SYSTEM COMPACT PRESSURE/LEVEL TRANSMITTER

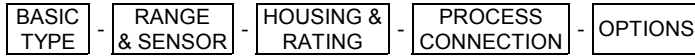

MODEL NO.: 551Y - G4Y - 4XT - 1/2" FPTY - AA

M/N	BODY MATERIAL
551Y	316 S.S.
551G	HASTELLOY "C"

M/N	DESCRIPTION
AA	NONE
PS	1/2" MPT CONDESATE PIGTAIL FOR STEAM; SERVICE

M/N *	FULL SCALE RANGES	
	U.S.A.	METRIC
G1 Y	40" H ₂ O G	0.1 BAR-G
G2 Y	80" H ₂ O G	0.2 BAR-G
G3 Y	200" H ₂ O G	0.5 BAR-G
G4 Y	15.0 PSIG	1.0 BAR-G
G5 Y	30.0 PSIG	2.0 BAR-G
G6 Y	60.0 PSIG	4.0 BAR-G
G7 Y	120.0 PSIG	8.0 BAR-G
G8 Y	250.0 PSIG	16.0 BAR-G
G9 Y	500.0 PSIG	40.0 BAR-G
G10 Y	1000 PSIG	80.0 BAR-G
A4 Y	15 PSIA	1.0 BAR-A
A5 Y	30 PSIA	2.0 BAR-A
A6 Y	60 PSIA	4.0 BAR-A
A7 Y	120 PSIA	8.0 BAR-A
V8 Y	0/-15 PSIV	0/-1 BAR-V
V9 Y	-15/+15 PSIV	-1/+1 BAR-V
V10 Y	-15/+30 PSIV	-1/+2 BAR-V
V11 Y	-15/+60 PSIV	-1/+4 BAR-V
V12 Y	-15/+120 PSIV	-1/+8 BAR-V

M/N (ANSI)	MAT	CONNECTION DESCRIPTION
1/2" FPTY	316 S.S.	1/2" FEMALE NPT
1" MPTY	316 S.S.	1" MALE NPT, OPEN FACE
1" MPTG	HAST "C"	1" MALE NPT, OPEN FACE
1" 150RY	316 S.S.	1"/150# R.F. ANSI FLANGE
1" 300RF	316 S.S.	1"/300# R.F. ANSI FLANGE
*2"150RY	316 S.S.	2"/150# R.F. ANSI FLANGE
*2"150RS	STEEL	2"/150# R.F. ANSI FLANGE
*2"300RS	STEEL	2"/300# R.F. ANSI FLANGE
*2"600RS	STEEL	2"/600# R.F. ANSI FLANGE
ZA	ANY	LAGER SIZES; OTHER FACES; OTHER STANDARDS - DIN, JIS, ETC.

* 1-1/4" AND 1-1/2" SIZES AVAILABLE, AT SAME PRICE

M/N	DESCRIPTION (ALL 4X)
4X*	ENVIRONMENT PROOF FLIP-TOP; 4X; ALUMINUM; S.S. TRIM; INTRINSICALLY SAFE, CLASSES 1 & 2, DIVISIONS 1 & 2, GROUPS ABCD, EFG
7W*	EXPLOSION PROOF; CLASSES 1 & 2; DIVISIONS 1 & 2; GROUPS BCD, EFG; ALUMINUM CONSTRUCTION
7*	EXPROOF, SAME AS ABOVE EXCEPT ALL 300 S.S. CONSTRUCTION

* REPLACE "*" WITH "F" FOR FLYING LEADS, OR "T" FOR TERMINAL STRIP IN HOUSING

RANGE REFERENCE TO:

"G" = ATMOSPHERIC PRESSURE
 "A" = HARD VACUUM
 "V" = BELOW ATMOSPHERE
 * "Y" = 316-L S.S. FACE (BASIC);
 HASTELLOY IS OPTIONAL TO 500 PSI:
 REPLACE "Y" WITH "G" AND ADD \$525.

FOR 2000 OR 3000 PSIG RANGE: ADD \$65.
 (NOT FOR THIRD PARTY LISTED)

APPROVALS:

CSA (CANADA)
 NRTL/C (USA)
 INTRINSICALLY SAFE
 EXPLOSION PROOF
 ENVIRONMENT PROOF

ISO 9001 QUALITY SYSTEM

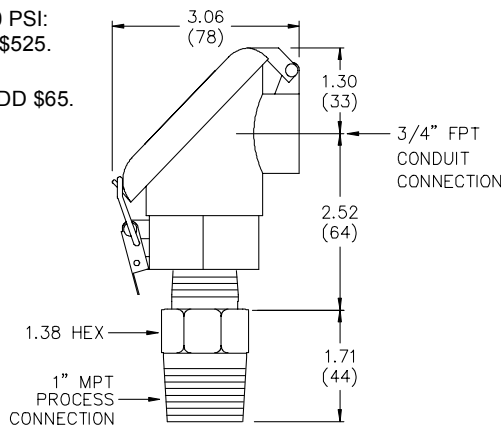

Model 551 With 4X
Flip-Top Housing

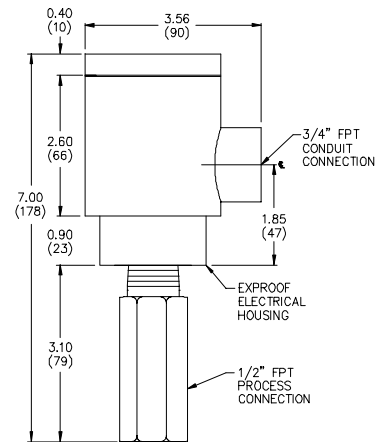

Model 551 With S.S.
Exproof Housing

DELTA CONTROLS

CORPORATION

Engineered Sensors - For Difficult Services
 585 Fortson Street
 Shreveport, La. 71107 - USA



Ph: +1(318) 424 8471
 Fx: +1(318) 425 2421
 E-mail: sales@deltacnt.com
 Web: www.deltacnt.com