

# MODEL 173 PROBE TYPE LEVEL TRANSMITTER

## DIGITAL CIRCUITRY FOR DEMANDING SERVICES

### PUSH-BUTTON CALIBRATION, NARROW RANGES

- 4-20 mA, 2 wire, loop powered
- Digital R.F. Admittance measuring circuitry
- Intrinsically safe probe circuit
- Insensitive to process coatings and buildup
- Simple, two point calibration. You don't have to empty (or fill) the tank to calibrate accurately
- Can be reverse calibrated at will (20 mA = empty tank)
- Built-in self-diagnostics warns of mis-calibration.
- Choice of integral or remote electronics module
- Corrosion resistant, NACE #MR-01-75 optional
- Intrinsically safe electronics design improves safety and lowers cost of installation and maintenance
- Process pressure as high as 10,000 psig (700 Bar)
- Process Temperature: -460 to +1500°F (-273 to +800°C)
- Wide choice of wetted materials includes 316 SS, Teflon<sup>®</sup>, Alloy 20, Kynar<sup>®</sup>, Monel, and Ceramics
- User interface LCD digital display with 4 key input
- Threaded, flanged, or bracket probe mounting
- Epoxy sealed electronics module survives harsh environments and area vibration
- The 173 is essentially 100% repeatable over its range.
- Built in voltage spike protection, heavy 12 gage terminals

#### APPLICATION

The Model 173 probe style transmitter is used for high reliability measurement of liquid level and interface position. It is insensitive to variations in liquid conductivity, fluid coatings, or solids buildup. The instrument utilizes highly stable crystal references and filters; this allows it to work on narrow ranges and to reliably transmit the level of low dielectric materials. Its sensing probe must be installed in the liquid container so that its active portion passes through the range of fluid elevation points to be measured. The probe is normally inserted vertically down into the liquid from the top of the tank or vessel. Probes can be provided for penetration or mounting at any angle and can be up to 100 feet (33m) long. The electronics module is potted in epoxy for improved reliability under conditions of vibration and corrosion.

It will accurately measure almost any kind of liquid, including: water, oil, gasoline, acid, caustic, soup, milk, gear lube, and antifreeze. It is particularly advantageous when used on fuel oil tanks, cooling tower basins, fruit juice, chlorine storage tanks, irrigation channels, and pharmaceutical reactors. It will also do a good job on some powdered and granular solids under controlled conditions. The isolated loop powered 4-20 mADC signal is ideal for driving controllers, displays, and supervisory computers.

It will correctly transmit the position of an interface by sensing the ratio of the admittance of the two liquids. Typical interfaces include oil/water, gasoline/acid, and foam/effluent. Interface control is important in crude oil separation, flotation mining, seed oil milling, and fuel tank sediment monitoring. The interface can be accurately detected even though it may be "cloudy" or be carrying a "rag layer."



Mounted in an explosion-Proof Housing



Mounted in a 4X PVC Housing with Cover Removed



**DELTA CONTROLS**  
CORPORATION

## OPERATION

The Model 173 utilizes digital admittance technology to measure how much of its sensing probe is covered by the media. This is accomplished by generating a radio frequency pulse of energy, which travels from the sensing probe to the ground reference (usually the tank wall). The amount of media present between the two determines how much energy is transferred. The energy flowing (very small and low level in all cases) is a highly repeatable measure of the media level or interface position. The amount is integrated and used to produce the 4-20 mADC material elevation signal.

## BASIC SPECIFICATIONS

**Level range:**.....Dependant on the probe selected, see Application Note # PROB –298 and probe data sheets.  
**Minimum Level Span (“QSU”):**.....40 Sensing Units  
**Maximum Range (“RSU”):** .....16,000 S.U.  
**“Zero” Suppression:** .....to 16,000 Sensing Units  
**Output:** .....4-20 mADC, 2 wire, loop powered, isolated  
**Loop Supply Voltage Range:** .....11-35 VDC  
**Max Loop Impedance:** .....650 ohms @ 24V, 1200 @ 35V  
**Ambient Operating Temperature:** .....-20 to +175°F (+80°C)  
**Process Temperature:** .....-460 to +1500°F (-270 to +810°C)  
**Accuracy and Stability:** .....Within 0.2% of full scale (limited to ±.05 S.U.)  
**Temperature Effect:** .....±2 Sensing Units; typically less than 0.2" in water; 0 to +150°F (-18 to 67EC)

## OUTLINE DIMENSIONS

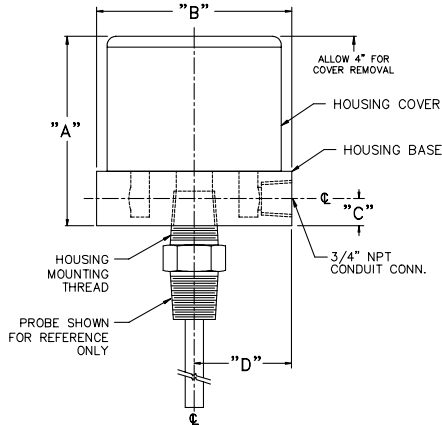

HOUSING RATING AND TYPE	DIMENSIONS			
	A	B	C	D
4X PVC	3.83	5.12	0.625	2.56
7X-P7	4.4	4.7	0.83	2.55

## MODEL NUMBERING SYSTEM

MODEL SECTION DESCRIPTION	BASIC TYPE	HOUSING & RATING	MOUNTING LOCATION	OPTIONS
MODEL EXAMPLE	173	4XR	20P	AA

M/N	DESCRIPTION
173	7500 SU MAX RANGE

M/N	DESCRIPTION
AA	None
PH4	4X PVC Probe Head Housing Required with Remote Module
PH7	Same except Explosion Proof
ZZ	Custom Configurations

M/N	DESCRIPTION
4X#	Hose Proof, PVC
7W#	Explosion Proof, Classes 1 & 2, Division 1, Groups, BCD, EFG; Also 4X Hose Proof Aluminum
7T#	Same as 7W, Except 300 S.S.

Replace “#” with one of the following:  
 “I” – Mounted integral on the Probe Head  
 “R” – Remote Surface Mounted (Interconnecting Cable Required)

M/N	DESCRIPTION
AA	None, Integrally Mounting
#P	Remote, Poly Jacketed Cable. 160° F (70° C) Max
#D	Remote, Teflon® Jacketed Cable. 450° F (230° C) Max

Replace # with Total Length of Cable Required, in Feet.

NOTE: M/N for Electronic Units only;  
 Specify Sensing Probes Separately

## MODULE LAYOUT AND WIRING

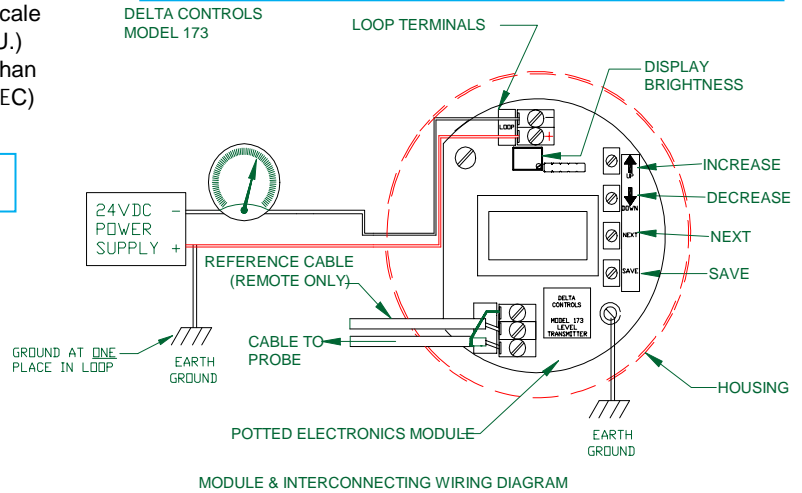

### Housings:

- Explosion-proof, Class 1, Division 1, Groups B,C,D, E,F,G; also 4X Hoseproof; Aluminum or 304SS
- 4X Hoseproof, PVC and 304SS

## THIRD PARTY LISTINGS

CSA (Canada) NRTL/C (USA)

DESIGNED AND BUILT IN THE USA  
 BY DELTA CONTROLS



Engineered Sensors – For Difficult Services

585 Fortson Street  
 Shreveport, La. 71107 - USA  
 Ph: +1(318) 424-8471  
 Fax: +1(318) 425-2421  
 E-mail: sales@deltacnt.com  
 Web: www.claustrmp.com