

MODEL 104 PROBE TYPE LEVEL SWITCH

TIP SENSITIVE ACTION FOR CONDUCTIVE LIQUIDS AND SOLIDS

ADJUSTABLE POINT LEVEL FOR NONCONDUCTIVE MATERIALS

FEATURES

- Works on liquids, slurries and solids
- 316 S.S. body and sensing rod, Teflon seals
- Solid rod or flexible cable sensing probe
- Probe length is field adjustable
- 10 Amp SPDT heavy duty output relay
- High-Low failsafe relay action selector
- Has an extended insulator, no cavity to plug up
- Up to 220°F (105°C) process temperatures
- Vibration resistant, no glass insulation seal to break or epoxy to fracture
- Up to 1500 psig (100 Bar) process pressure
- Secondary over pressure stop provides a metal-to-metal seat against catastrophic leaks
- Teflon rod seal is reliable (unlike epoxy or glass)
- High reliability; 100 hour operationally tested
- Quality assured; 100% tested and inspected
- Integrating 1 second time delay standard

APPLICATION

The Model 104 probe type control switches when a conductive material touches the tip of the sensing probe. More of the sensing probe must be covered when the material is insulating and has a lower dielectric constant. The Model 104 will sense almost any sort of material, even insulators with a low density and a medium dielectric constant.

The unit is designed to detect high or low levels of liquids, slurries and solids. It is designed for mounting on the top of a tank, container, or open pit for high level detection. It is intended that the sensing probe extend down from the top to the point at which level switching is to occur. The unit can also be mounted so that its sensing probe extends in from the side of the container. This side mounting position should be limited to dry solids applications. Slurry tanks should be entered only from the top.

TYPICAL SERVICES

- High level alarm in liquid storage tanks
- Cement hopper high and low level alarms
- Beer and beverage vat level alarms
- Raw and sliced potato bin levels
- Pumping gallery flood alarm
- Aquaculture water and nutrient systems
- Subsea oil production modules



Hoseproof housing,
R0 sensing probe



Explosionproof housing,
R0 sensing probe

OPERATION

The Model 104 is insensitive to buildup on the tip of its sensing probe. The deposited buildup material can be wet, sticky, or even an insulator. Recalibration or cleaning may be required under conditions such as extreme candling, glacial salt bridging, etc. Radio frequency technology is the basis for this new and improved level control design. An advanced sensing method, using pulsed radio frequency waves, is the heart of this new circuit technique. This method produces excellent stability and good accuracy. False switching problems have essentially been eliminated by this design. High-speed filtering and noise rejection provide highly reliable level detection and switching.

MODEL NUMBERING SYSTEM

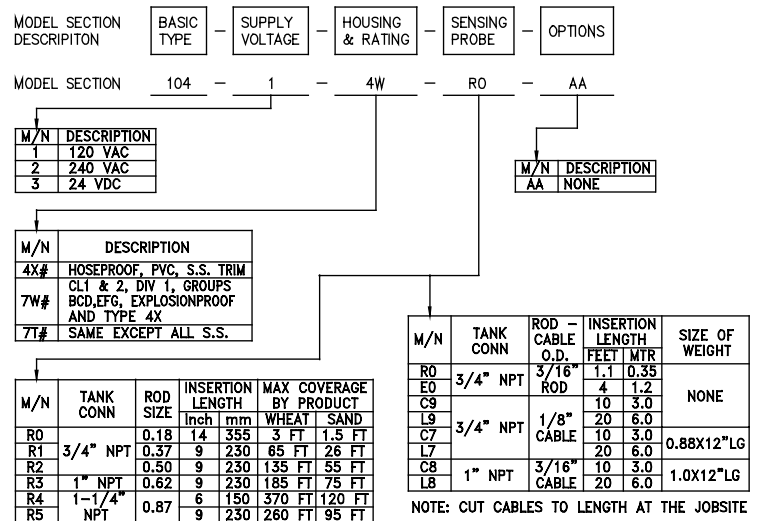

BASIC SPECIFICATIONS

Switching Differential ("DSU"): Fixed 4.0 SU minimum

Minimum Probe Gain Require ("QSU"): 8.0 SU

Wetted Materials: 316 Stainless steel body & rod; Teflon® and Delrin insulators, seals

Output: SPDT relay contacts, 10A @ 250 VAC

Action: Direct/Reverse, with failsafe selector

Relay condition: Indicated by bright LED

Time delay: Integrating type, 1 second delay

Accuracy: Better than 0.50% full scale

Repeatability: Better than 0.10% full scale

Process temperature: -20° to +230°F (110°C)

Temperature effect: 0.50% full scale per 50°F (28°C) ambient change in temperature

HOUSING DIMENSIONS

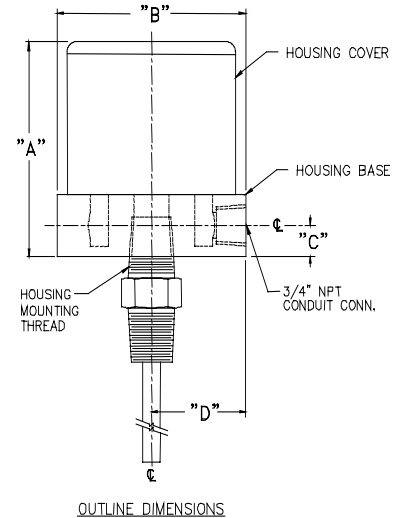

HOUSING TYPE	DIMENSIONS IN INCHES			
	A	B	C	D
4W	3.47	4.50	0.625	2.56
7W	4.10	4.65	0.83	2.55

MODULE LAYOUT AND WIRING

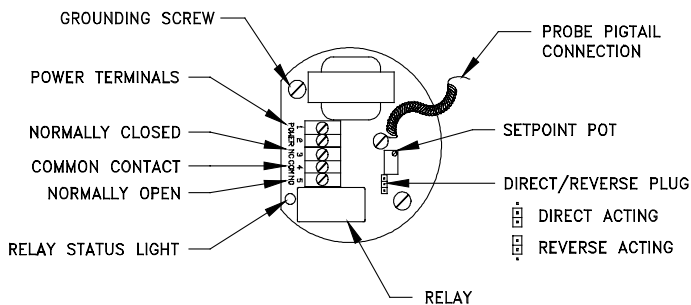

DESIGNED AND BUILT IN THE USA
BY DELTA CONTROLS

THIRD PARTY LISTINGS

HOUSING: EXPLOSIONPROOF, CLASS 1, DIVISIONS 1 & 2; GROUPS BCD, EFG, ALSO 4X HOSEPROOF

CSA (CANADA) NRTL/C (USA)

ISO 9001 QUALITY SYSTEM

RIGID SENSING PROBES FOR HIGH ALARM, MOUNTED ON TOP OF METAL TANKS

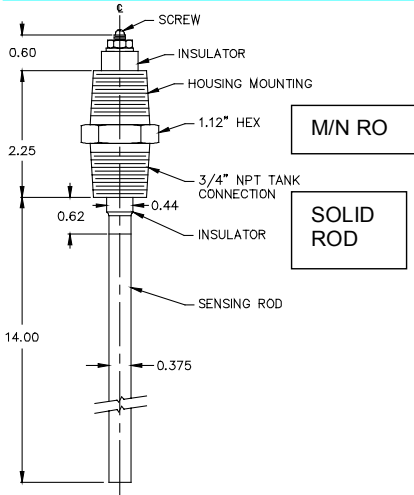

M/N RO

SOLID ROD

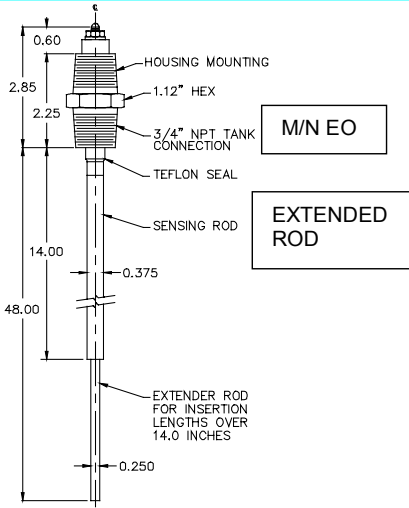

M/N EO

EXTENDED ROD

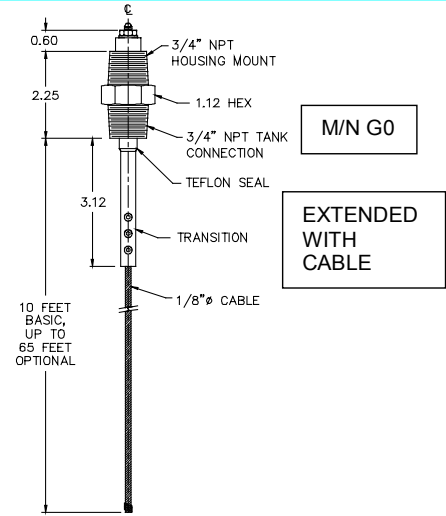

M/N GO

EXTENDED WITH CABLE

FLEXIBLE SENSING PROBES FOR MOUNTING ON TOP OF METAL TANKS

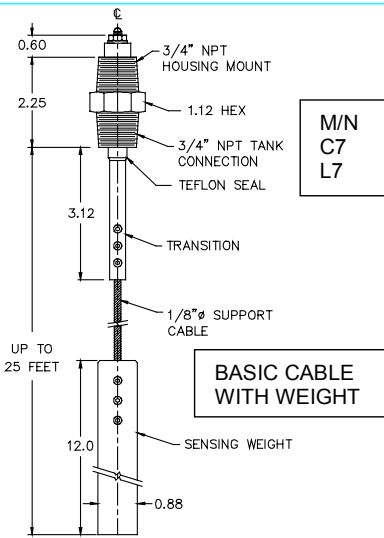

M/N C7 L7

BASIC CABLE WITH WEIGHT

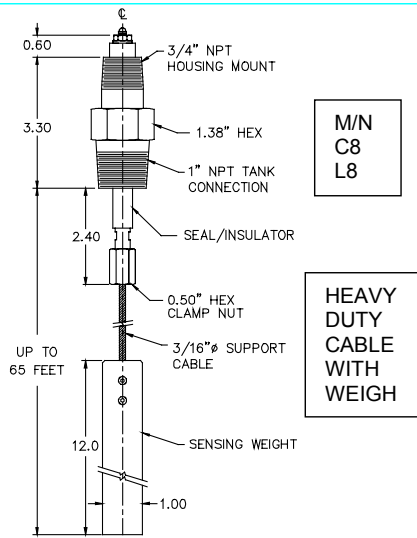

M/N C8 L8

HEAVY DUTY CABLE WITH WEIGH

SPECIFICATIONS

Note: All rods and cables may be shortened in the field.

For: R0, E0, C9, L9

Wetted Materials: 316 S.S. and Teflon

Design Conditions

- (1) Blowout proof stop
- (2) Operating conditions:

Temperature	PSIG	BAR
100°F	30°C	1000
350°F	180°C	100
400°F	205°C	15

For: C7, C8, L7, L8

Wetted Materials: 304 S.S. and Delrin (Acetal)

Temperature: 260°F (125°C) maximum

Pressure: -1 to 150 PSIG (10 BAR) maximum

DETERMINATION OF SWITCHING POINTS

Conductive Materials: Switching will occur when the material touches the tip of the probe.

Nonconductive Materials: Switching will occur when some of the sensing probe length has been covered by material. Determine that the inches of "On" to "Off" level differential is acceptable in the application under study.

- A. Read "QSU" (total SU) from graph below. Note: "QSU" must be at least 1.0 SU. Be sure that the Dc value used is corrected for the actual bulk density of the material.
- B. Determine "DSU" (inches switching differential): Divide 8.0 by the "QSU" value. A "DSU" of over 6 may be unsatisfactory.
- C. Minimum required probe length: Twice the above determined "DSU" value.

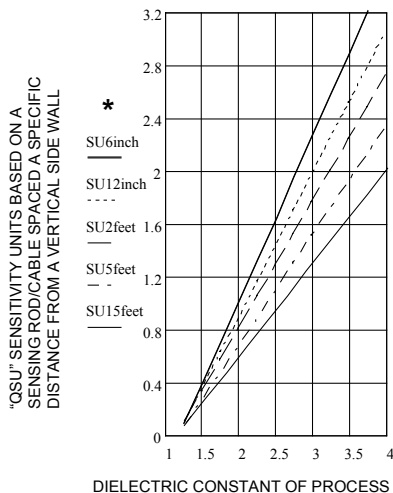

* DISTANCE TO TANK WALL, USE "15 FEET" FOR THRU A LARGE SURFACE

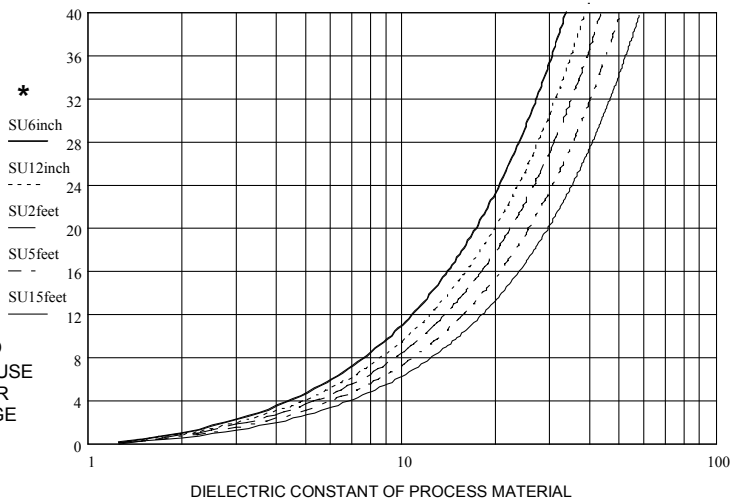

RIGID ROD PROBES TO BE SIDE INSERTED INTO METAL TANKS

ALL MODELS - Temperature: 260°F (125°C) maximum Pressure: To 250 PSIG (17 BAR) maximum. Materials: 304 S.S., Teflon®, Delrin®

R1 FOR GRANULAR SOLIDS

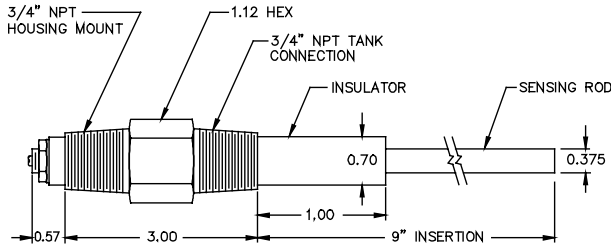

R3 FOR TALL SILOS AND FLOWING GRANULES

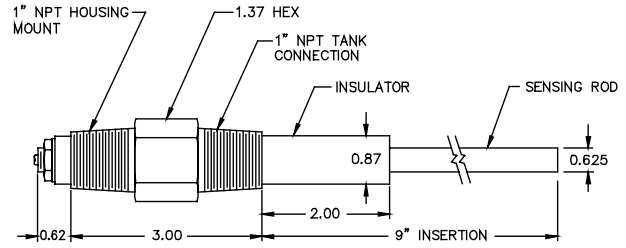

R2 FOR TALLER SOLIDS TANKS AND SILOS

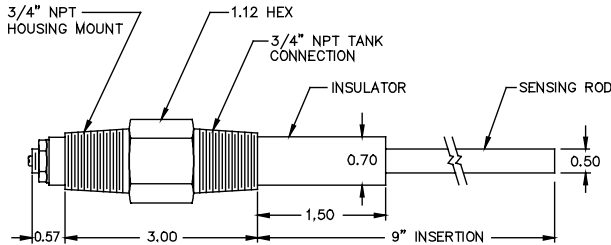

R4 FOR VERY ROUGH SOLID SERVICES

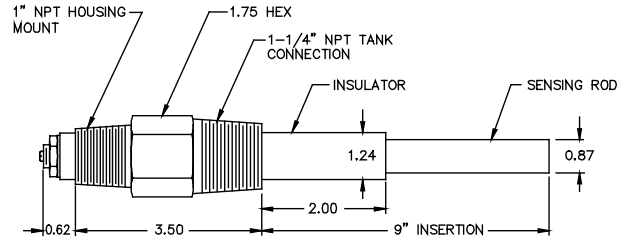

ESTIMATING PROBE PERFORMANCE

DETERMINE "QSU" – Series R probes are normally only used for single point on-off alarm service. "QSU" is the number of sensing units due to the probe length being covered by the process material. Read "QSU" from the graph below. "QSU" should be greater than 8.0 for use with the M/N 104 module. Note: Probe rods may be shortened by sawing in the field.

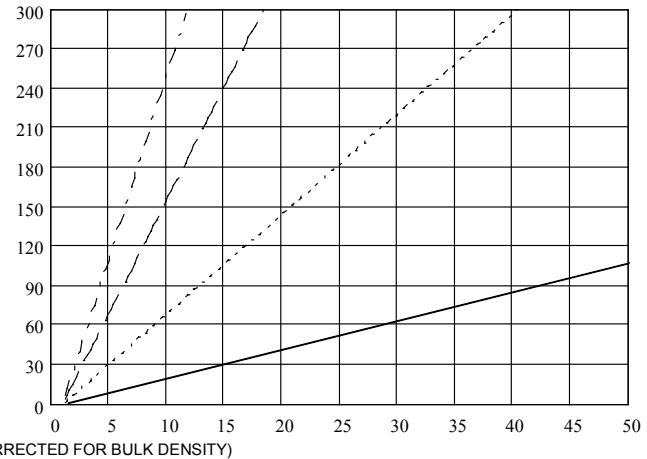
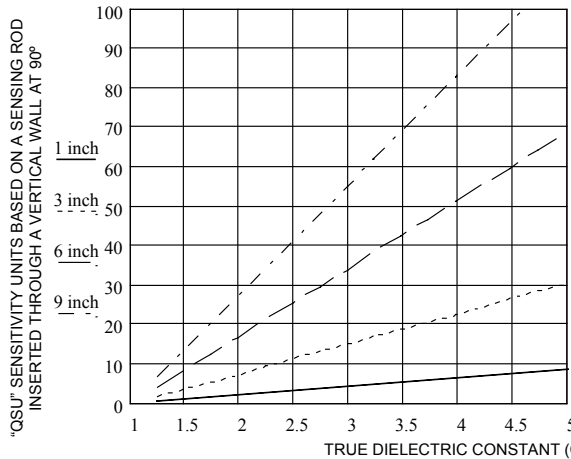

MAXIMUM ALLOWABLE ELEVATION OF MATERIAL

The horizontal sensing probe can withstand heavy (but not unlimited) loads without bending or failing. The loading on a probe is a function of the density of the material, how deeply the sensing probe is covered, and the probe rod size and position. Delta Controls has simplified this complex relationship into a simple one which is easy to use. The result is a term called "Weight Factor" or "WF". A "WF" value has been derived for each probe model. The maximum amount of coverage is easily determined by dividing "WF" by the bulk density of the process material; as follows:

$$\text{MAXIMUM COVERAGE} = \frac{\text{"WF"}}{\text{LBS/FT}^3} = \text{HEIGHT OF MATERIAL IN FEET}$$

WEIGHT FACTORS (9" probes)

M/N	R1	R2	R3	R4
"WF"	3,150	6,590	8,880	14,900

EXAMPLE: Whole kernel corn, 48 LBS/FT³.
Using a Model R2 sensing probe
Maximum Coverage = $\frac{6590}{48} = 137$ FEET (42 M)

DELTA CONTROLS Corporation

585 FORTSON STREET
SHREVEPORT, LA. 71107 - USA
PHONE: 318-424-8471 FAX: 318-425-2421

e-mail: delta@deltacnt.com Web Site: <http://www.deltacnt.com>

